



## Reverse Lights & Work Lights

Full-LED



## **CONTENTS**

### **Introduction - Ermax Lighting Systems**

Ermax Lighting Systems and distribution network 4

### **Work Light LED**

Innovative design & highest quality 6

Modern light- and LED technology 8

Quality standards and test methods 10

Application areas 12

Standard programme with large flexibility 13

Universally applicable 14

Easy maintenance 15

### **Product Programme**

Technical features and advantages 16

Reverse lights LED 17

Work lights LED 18

### **Spare parts & Accessories**

Plug connections 23

Extension cables and Y-Adapter cables 24

# ERMAX® - Your partner for complete Lighting systems

## ERMAX A/S

- develops, manufactures and distributes a wide range of products within lighting, junction boxes and cable systems for commercial vehicles and industrial applications.

A unique set-up with a combination of our factory in Denmark and licensed production with our own tools at a number of selected and exclusively certified partners worldwide, offers an extensive, highly competitive and qualitative range of products.

## The Brand - ERMAX®

Founded in 1948 the Ermax® lighting technology has been manufactured for the automotive industry for almost 7 decades.

Ermax is the partner, when it comes to understanding and fulfilling the needs of lighting; with tail lights, warning lights, beacons, side markers or work lights – nowadays bulb, LED as well as in hybrid technologies. These lighting components are being offered within a complete solution concept of ADR approved

cables and, where required, junction boxes as well as mounting hardware. All cable sets are configured with multiple connector types to ensure the best lifetime service ability.

## Why Ermax® Lighting Systems ?

Partnership through quality, reliability and competence.

Our competence in partnering with you, is our extensive experience in being an OEM partner with quality and on time delivery as daily focus to ensure expectations and execution match entirely with your requirements.

All our products hold the necessary certifications for E-marking, IP-protection, ADR-approval and design preconditions to ensure exclusive design and durability as well as non-violation of patents.

**With reliable and planned processes you will reach your goal safely with us as partner.**



ERMAX A/S, Kolding, Denmark

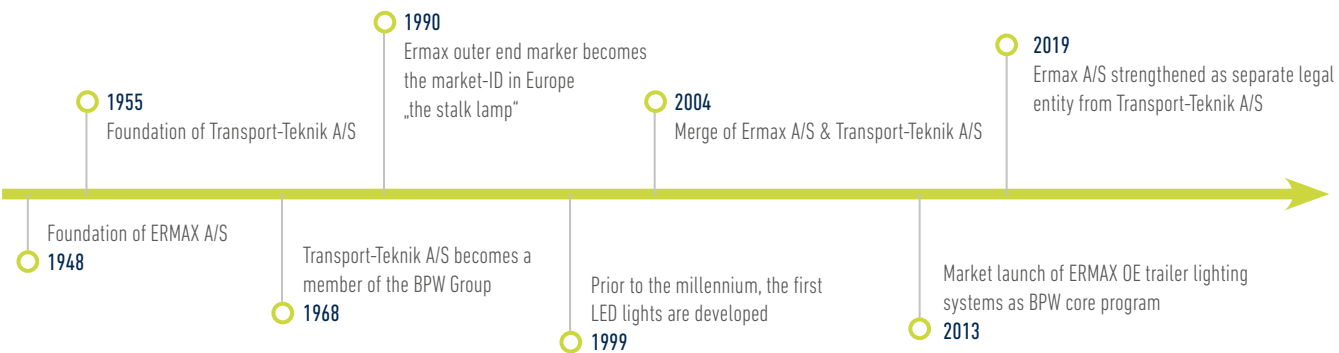

## Distribution network worldwide

### Always close to you

As a member of the BPW Group, which operates worldwide, we have an unique sales and distribution network with local offices and support for the benefit of all of our business partners.

- BPW Service: mobility around the clock  
– thanks to 3,200 service partners around the world



## SOLUTIONS – AS INDIVIDUAL AS YOUR TASKS AND REQUIREMENTS

### As ERMAX customer you will achieve the following

- High quality for every area
- Vehicle customised solutions
- Focus at the newest technology and innovative products with recognisable design
- Production companies with development competence under one roof
- Europe-wide after sales servicenet

### ERMAX lighting systems

- Wide palette including cables, plugs and lights – all built according to customer requirements
- LED and SIMAC control unit built-in tail light
- ADR approved cable kits with 7 pole AMP 1.5 and Super Seal plugs
- Unbeatable, impact resistant and long life solutions

# Innovative design & the highest quality

Modern light- and LED technology for better work light

## The compact and modern reverse & work light from ERMAX

The ERMAX work light programme fulfills the highest demands concerning quality, functionality and reliability. The innovative LED technology ensures a long life-time, energy efficiency and high capacity - and the maintenance and stand still times are all reduced to a minimum.

Unique design, latest light- and LED technology, unbeatable durability and high quality are united in the ERMAX work light programme - and due to the cost-effectiveness, a real highlight.

The ERMAX work lights are suitable for all applications, where efficient high quality light is necessary in order to work more productively and safely - day and night - also when the work lasts for many hours.

The material used fulfills all demands for high stability and impact resistance against shock, vibration, dirt and moisture.

The work lights are of high quality and suitable for demanding tasks.

## Why ERMAX

### Clear lens - Unbeatable

Impact-resistant lens made of polycarbonate. Less loss between the nominal and effective lumen due to the clear lens.

### High Power LEDs

Long-life LED Technology - LEDs with extremely long life-time up to 50.000 hours.

### Electromagnetic discharging

The arrangement of the LEDs and the build method of the reflector ensure that no interfering magnetic field will occur.



### Light distribution

The reflectors are so developed that the light is optimally utilised.

## ERMAX Work Lights LED

Work safer and more productively in a clear light

### The Highlights in overview

- Innovative development, design and the highest product quality
- The most modern light- and LED technology – high light performance and homogenous distribution of the light
- Unbeatable – polycarbonate impact-resistant lens
- Compact design - universally applicable
- Application as reversing light when angled (ECE-R23)
- First-class tested OEM quality



#### Surface coating

Strong coating, also in holes and threads. Protects the aluminium parts from corrosion.

#### Effective heat derivation

Surplus heat from the LEDs will be efficiently dispersed due to their position.

#### Overheating and reverse polarity protection

Protected against overheating and reverse polarity.

#### Bracket of steel AISI 304 quality

Austenitic steel with acid-resistant properties. Due to its high formability, it is ideal as a bracket.

#### Usable everywhere

The compact design brings a lot of flexibility in the field of mounting options.

# The most modern light- and LED technology for better work light

## High light output, Homogeneous light distribution & long lifetime

The development of the new ERMAX work light starts with a light technical process. The light technique in the LED area is in a rapid development and thus there are no standard solutions. Each new work light has to be recalculated. The results flow into the design of the reflectors and in the optimal selection of the LEDs.

In the light technical process the light distribution is defined. The reflector design as well as the arrangement of the LEDs are important for the light distribution, in order to get a homogenous illumination.



## Which variant of the ERMAX work lights to choose - and which lumen ?

The ERMAX work lights are available in 3 design variants with 3 different light outputs / lumens. The more far reaching the desired illumination, the more light intensity / lumen is needed. The work light has a strong local illumination. The greater the need for long-range illumination, a work light with greater light intensity / lumen must be selected.



Lumen  
Theoretical 800 / Effective 600

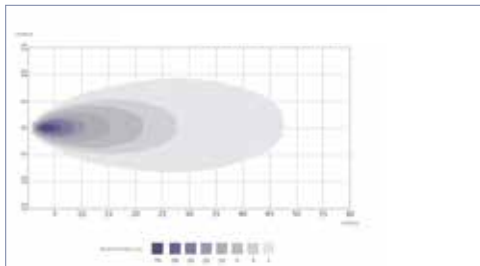

Lumen  
Theoretical 1600 / Effective 1200

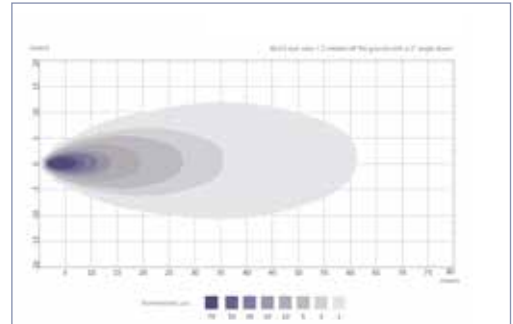

Lumen  
Theoretical 2400 / Effective 1800

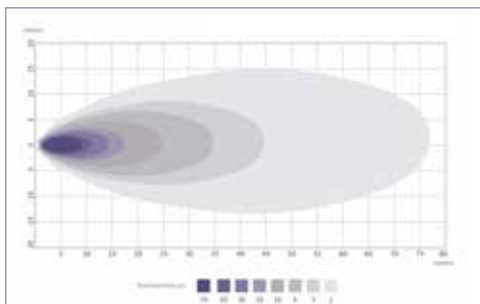

Lumen  
Theoretical 3.200 / Effective 2.400

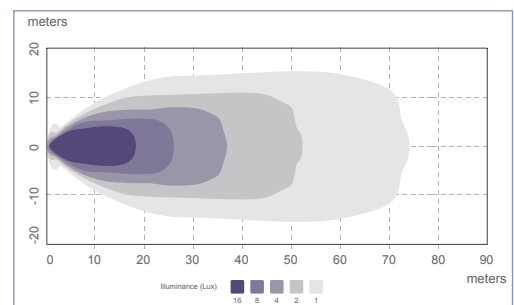

Bird's eye view 1,2 meter above the ground with an incline angle of 5°

In order to achieve optimal utilisation of the effective lumen, the homogeneous distribution of the light is very important. The ERMAX work lights are technically so developed that the difference between the theoretical and the effective lumen is being reduced. The following aspects are crucial for this:

### ➤ Reflector Systems

The reflectors for a homogeneous light distribution are calculated in such a way, that the light concentration in the close range is reduced and will increase constantly with the distance.

### ➤ The quality of the lens material

Thanks to the impact resistant lens made of polycarbonate, the light output remains homogeneous even after a severe blow or under hard working conditions.

### ➤ Quality of the LED light source

The newest technology is used to achieve an extreme long lifetime – up to 50,000 hours using LEDs.

# First-class tested quality from ERMAX

## Quality standards and test methods

Ongoing in the manufacturing process, the defined quality criteria and test methods of the ERMAX work lights are checked in order to guarantee the high product quality. Numerous complex test procedures are carried out and the quality is ensured by observation, monitoring and testing.



### Temperature / humidity cycle test

The ERMAX work lights are going through a temperature cycle test in climatic chambers with temperature fluctuations from  $-40\text{ }^{\circ}\text{C}$  to  $+65\text{ }^{\circ}\text{C}$ . During this test, the materials used for the work light, the individual components of the electrical components and the LED light sources are tested.

---



### Vibration test

During the vibration test the ERMAX work lights are being shaken for hours in order to simulate the toughest conditions in the daily use. The products are tested in all possible mounting positions (horizontal, vertical etc.).

---



### Splash water test

In a splash water chamber, the ERMAX work lights are tested for simulated rain and water jets, and also tested for density/tightness with a water pressure of 1 bar and a water temperature of  $20\text{ }^{\circ}\text{C}$  (IP54).

---



### Immersion and pressure tightness test

In the immersion test, the ERMAX work lights are under water lowered for 1 hour in a water tank in a depth of 1 meter (IP67).

---



#### Pressure washer test

The ERMAX work lights are subjected to a test with a water pressure of 80-100 bar and a water temperature of 80 °C (IP69K).

---



#### Dust test

The dust test according to IEC60529 uses dust to check how safety the ERMAX work lights are protected towards the ingress of dust and other solid particles.

---



#### Salt Spray test

In the salt spray test, the ERMAX work lights are tested in a chamber in order to test the corrosion resistance. High salt spray resistance is required because of harsh environmental conditions - especially when the work lights are mounted at the bottom of the vehicle.

---



#### Impact test

This test ensures the impact resistance of the ERMAX work lights in daily use. From a height of 0,4 meter, the work lights are tested with an 1 kg steel ball .

---

## ERMAX Work lights – suitable for every application

### Commercial, agriculture & forestry and Off-Road vehicles

ERMAX Work lights are suitable for all applications where a good and efficient lighting is necessary in order to work more productively and safely – day and night – also when the work lasts many hours.



#### Truck- and special vehicles

The work is often done in darkness and it is important for the security that the working area is well lighted up.



#### Trailer

Work lights are often mounted at the front, at the back or at the side of the trailer in order to ensure the utmost security when loading and unloading.



#### Agricultural and forestry

The work is done with many interruptions and during many hours – day and night – the working area must be illuminated in the best possible way.



#### Off-Road

Tough working conditions demand good lighting – with a long life and utmost light performance.

## Standard product programme with large flexibility

### Compact design, universally applicable and various connection possibilities

ERMAX reversing lights and work lights are available in 3 design types with different light performances / lumen.



LED Reverse light

Lumen:  
Theoretical 650 / Effective 300



LED Work light

Lumen:  
Theoretical 800 / Effective 600



LED Work light

Lumen:  
Theoretical 1600 / Effective 1200

Approved as reversing light (ECE -R23) with 30° angling by vertical mounting



LED Work light

Lumen:  
Theoretical 2400 / Effective 1800

Approved as reversing light (ECE -R23) with 35° angling by vertical mounting.



This type is also available with handle and on/off switch.



LED-Arbeitsscheinwerfer

Lumen:  
theoretisch 3.200 / effektiv 2.400

## Universally applicable

### Mounting options

ERMAX working lights have a compact design with measures meaning that they can be mounted in a very narrow place. The compact design and symmetric light distribution give a large degree of flexibility when mounting. The work lights can be standing, hanging, rear or side mounted.

#### Mounting options ERMAX work lights



Standing



Hanging



Side



Rear



# Easy maintenance

## Various connection variations

ERMAX work lights are available with various connection variations – connection cable with Open end, Super Seal socket or “Deutsch” socket. For connector variants, Ermax always offers a standard cable length of 300 millimeters to the first plug connection. The cable length can be adjusted according to need by means of standard extension cable or adapter cable. This ensures optimum ease of maintenance. The large variety of cable solutions ensures the best installation without having to adjust the cable length (see page 23-27).

### Connection / Extension possibilities ERMAX work lights



- Connection:
- Super Seal socket
- Super Seal plug
- Deutsch socket (DT2)

#### Extension cable with Super Seal connection

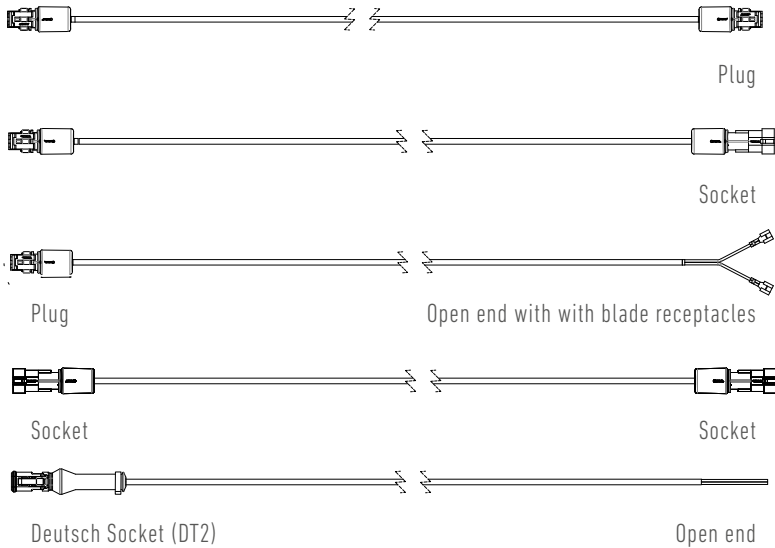

#### Y-Adapter with 3 x Super Seal plugs

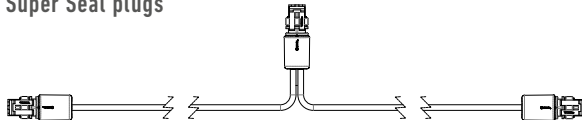

#### Reverse light connected as a chain -connected by a side cable with 1 inlet and 2 outlets with Super Seal plugs

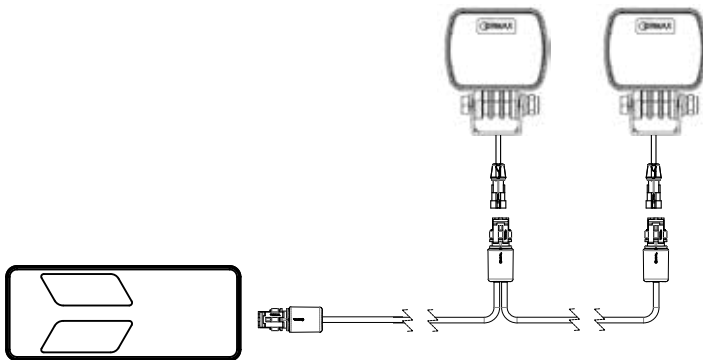

2 pieces of Ermax reverse lights or work lights are allowed to be connected to an Ermax tail light (Max 52W)

## Technical features ERMAX reverse lights and work lights

### Technical specifications - Common to all variants

- Impact-resistant lens made of polycarbonate
- Housing made of aluminium, black lacquer (anti corrosion layers)
- Mounting bracket made of stainless steel, AISI 304 quality
- Mounting bolts M8 / 30 mm
- Multivolt 12/24V
- Working temperature -40 °C bis +65 °C
- Flood light pattern
- Colour temperature 6.500 °Kelvin
- Protection class IP69K
- Overheating and reverse polarity protection
- ADR and EMC/R10 approved
- ECE-R23 approved

### Advantages of the newest LED light technology

- which are optimally utilised in the Ermax reverse lights and work lights

The advantages of the newest LED technology, which are optimally utilised in the ERMAX reverse lights and work lights - result in a product with a very high quality and extremely long life - and thus cost-effectiveness, which is a real highlight.

- High light output
- Extremely long lifetime
- 100% water & dustproof
- Low power consumption
- Maintenance free
- High shock and vibration resistance
- Effective heat conduction
- Increased profitability

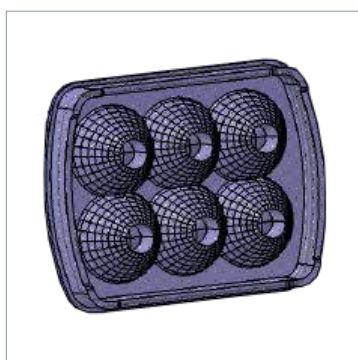
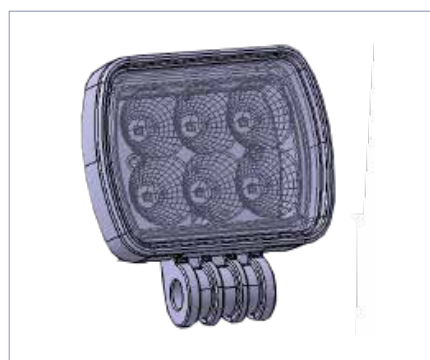

# Reverse Light

Theoretical Lumen 650

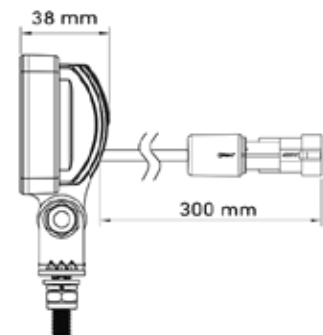
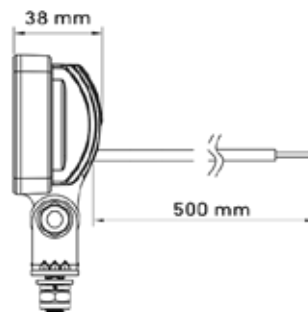
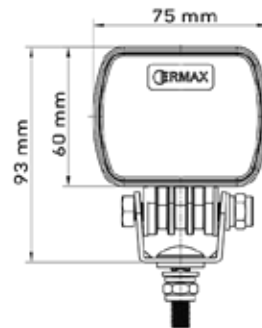

## Illumination

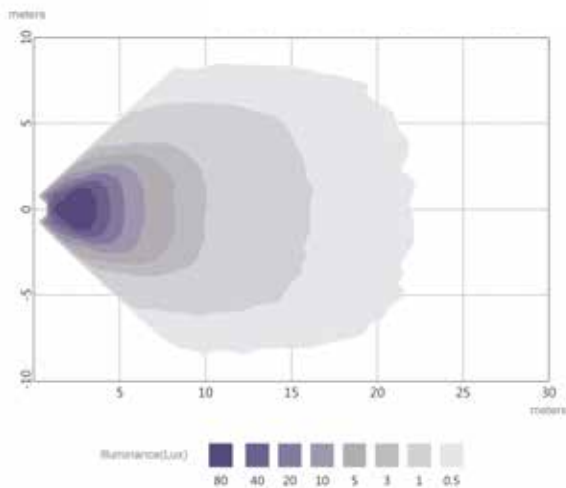

Bird's eye view 1,2 meter above the ground with an incline angle of 5°



Operating voltage	Energy consumption	Connection	Cable length	Light source	Lumen Theoretical / effective	Light pattern	Article No.
12/ 24 V	6,5 W	Open end	500 mm	6 x high-powered LED	650 / 300	Flood	098 256 250
12/ 24 V	6,5 W	Super Seal plug	300 mm	6 x high-powered LED	650 / 300	Flood	098 256 254
12/ 24 V	6,5 W	Super Seal socket	300 mm	6 x high-powered LED	650 / 300	Flood	098 256 255

# Work Lights LED

Theoretical Lumen 800

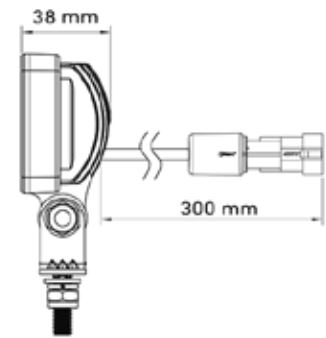
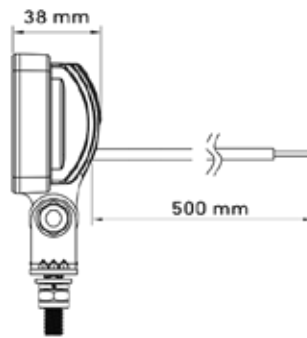
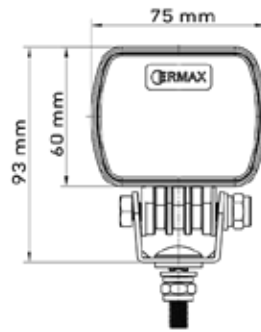

## Illumination

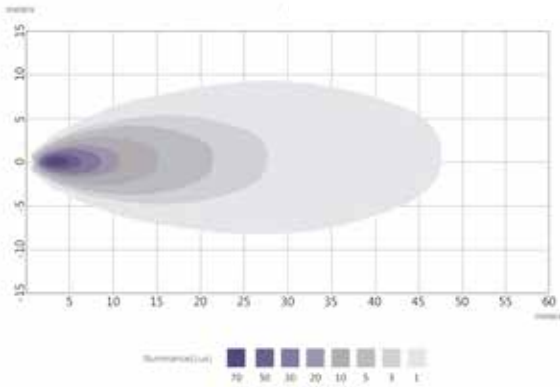

Bird's eye view 1,2 meter above the ground with an incline angle of 5°



Operating voltage	Energy consumption	Connection	Cable length	Light source	Lumen Theoretical / effective	Light pattern	Article No.
12/ 24 V	8 W	Open end	500 mm	6 high-powered LED	800 / 600	Flood	098 174 250
12/ 24 V	8 W	Super Seal plug	1.000 mm	6 high-powered LED	800 / 600	Flood	098 174 254
12/ 24 V	8 W	Super Seal socket	300 mm	6 high-powered LED	800 / 600	Flood	098 174 255

# Work Lights LED

Theoretical Lumen 1.600

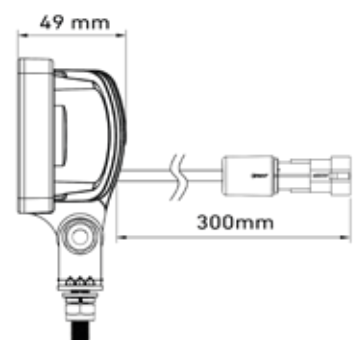
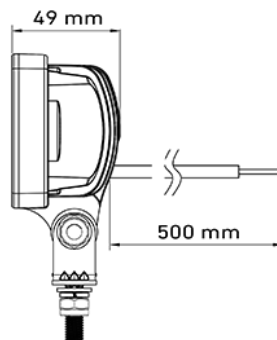
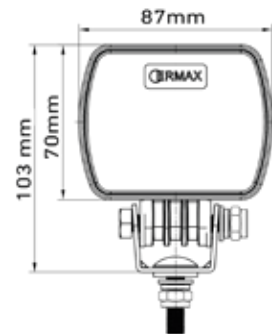

## Illumination

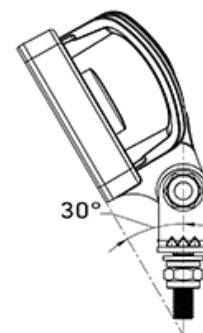
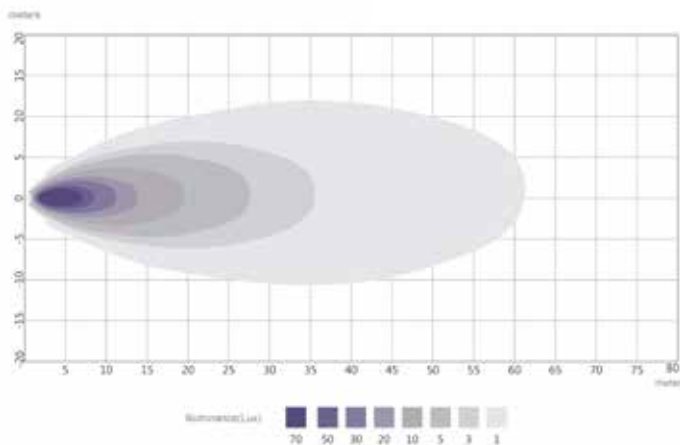

Approved as reverse light  
- with 30° tilt when vertical mounted



Bird's eye view 1,2 meter above the ground with an incline angle of 5°

Operating voltage	Energy consumption	Connection	Cable length	Light source	Lumen Theoretical / effective	Light pattern	Article No.
12/ 24 V	16 W	Open end	500 mm	9 high-powered LED	1600 / 1200	Flood	098 174 260
12 / 24 V	16 W	Super Seal plug	1.000 mm	9 high-powered LED	1.600 / 1.200	Flood	098 174 264
12/ 24 V	16 W	Super Seal socket	300 mm	9 high-powered LED	1600 / 1200	Flood	098 174 265
12 / 24 V	16 W	Integrated Deutsch (Dt) socket	--	9 high-powered LED	1.600 / 1.200	Flood	098 174 267

# Work Lights LED

Theoretical Lumen 2.400



Pos. 1  
Without on/off switch



Pos. 2  
With bracket and on/  
off switch

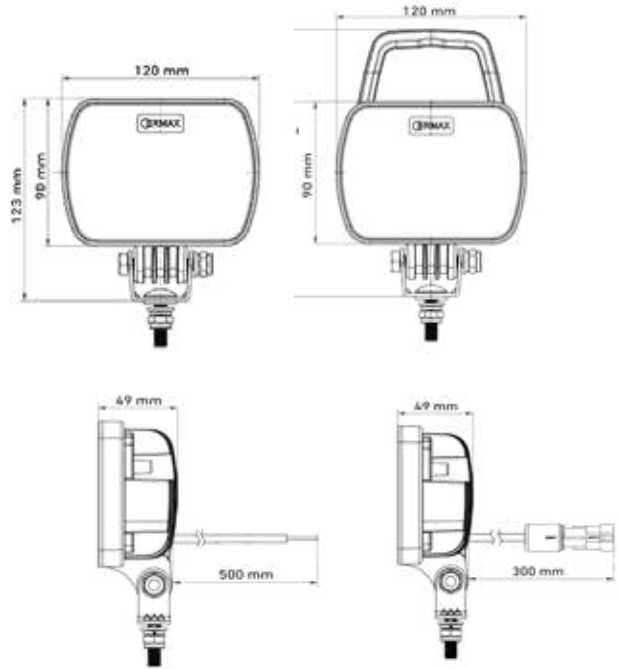

## Illumination

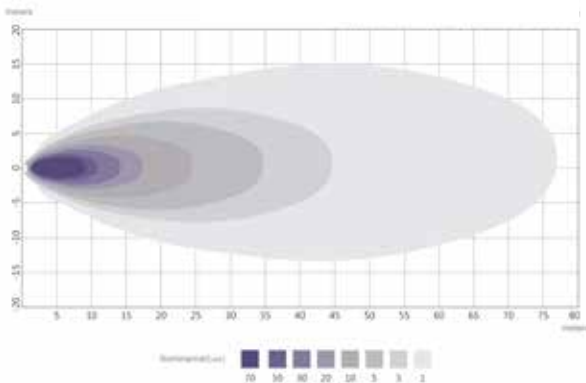

Bird's eye view 1,2 meter above the ground with an incline angle of 5°

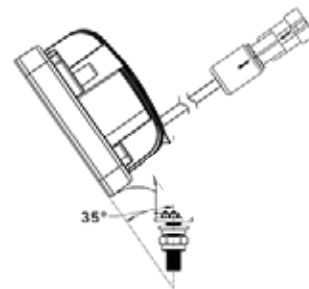

Approved as reverse light  
- with 35° tilt when vertical mounted



Operating voltage	Energy consumption	Connection	Cable length	Light source	Lumen Theoretical / effective	Light pattern	Pos.	Article No.
12/24V	25 W	Open end	500 mm	12 high-powered LED	2.400 / 1.800	Flood	1	098 174 270
12 / 24 V	25 W	Super Seal plug	1.000 mm	12 high-powered LED	2.400 / 1.800	Flood	1	098 174 274
12/24V	25 W	Super Seal socket	300 mm	12 high-powered LED	2.400 / 1.800	Flood	1	098 174 275
12 / 24 V	25 W	Integrated Deutsch (DT) socket	---	12 high-powered LED	2.400 / 1.800	Flood	1	098 174 277
12/24V	25 W	Super Seal socket - with handle & switch	300 mm	12 high-powered LED	2.400 / 1.800	Flood	2	098 174 279

# Work Lights LED

Theoretical Lumen 3.200

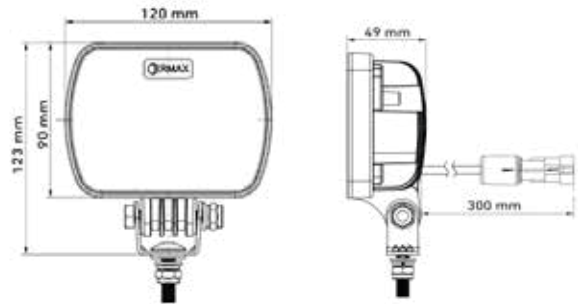

Illumination  
meters

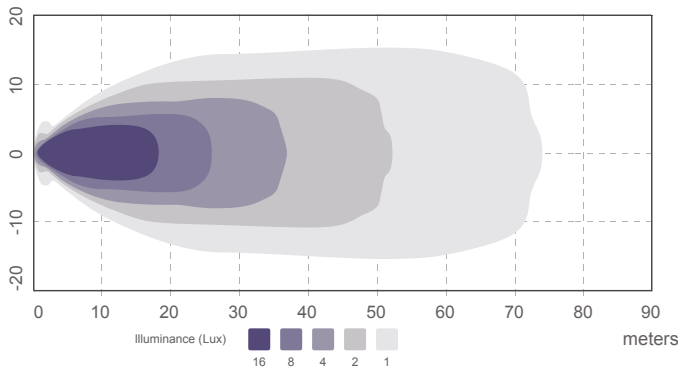

Bird's eye view 1,2 meter above the ground with an incline angle of 5°

EMC

Operating voltage	Energy consumption	Connection	Cable length	Light source	Lumen Theoretical / effective	Light pattern	Pos.	Article No.
12 / 24 V	25 W	Super Seal socket	300 mm	12 high-powered LED	3.200 / 2.400	Flood	1	098 174 285
12 / 24 V	25 W	Integrated Deutsch (DT) socket	---	12 high-powered LED	3.200 / 2.400	Flood	1	098 174 287

# Addition to a strong family

Further variants of ERMAX work lights

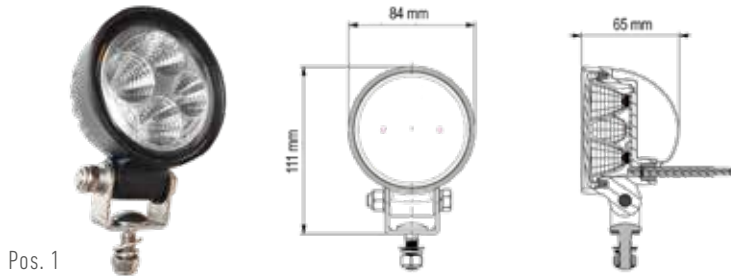

Pos. 1

## Illumination

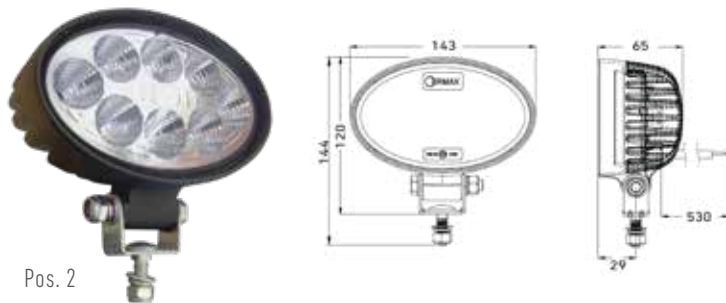
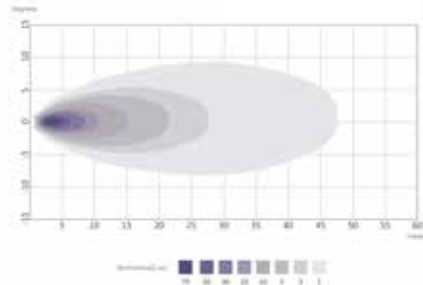

Pos. 2

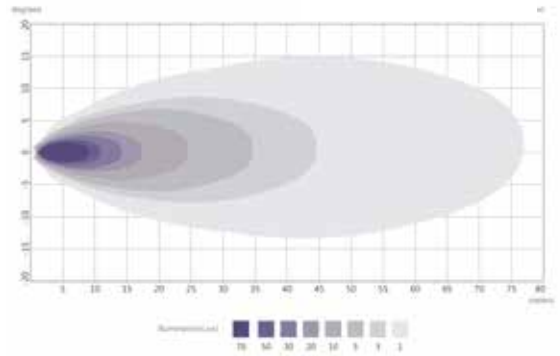

EMC

Operating voltage	Energy consumption	Connection	Cable length	Light source	Lumen Theoretical / effective	Light pattern	Pos.	Article No.
12/24V	12 W	Open end	500 mm	4 x LED	1.000 / 600	Flood	1	098 174 080
12/24V	24 W	Open end	500 mm	8 x LED	2000 / 1400	Flood	2	098 174 095

# Plug connections – spare parts and accessories

## ERMAX Reverse Lights & Work Lights

The ERMAX plug connector accessory programme offers solutions for almost any application.

Matching mount brackets can also be found in our programme.



Pos. 1



Pos. 2



Pos. 3



Pos. 4



Pos. 5



Pos. 6



Pos. 7



Pos. 8



Pos. 9



Pos. 10

Spare parts and accessories		Article No.
Mounting bracket for 37 mm light fixation - Kit set with	1	098 296 174
Mounting bracket aluminium, 31,5 x 30,5 x 17 mm. Ø61-65 mm	2	098 295 750
Mounting bracket aluminium, 32,5 x 31,5 x 18 mm. Ø66-71 mm	2	098 295 752
Super Seal plug 2 poled, Diameter yellow seal Ø 1,8 - 2,4 mm, Blade receptacle 0,5 - 1,0 mm <sup>2</sup>	3	099 110 019
Super Seal socket 2 pole, Diameter yellow seal Ø 1,8 - 2,4 mm, Blade receptacle 0,5 - 1,0 mm <sup>2</sup>	4	099 110 018
Rubber grommet for 2 pole Super Seal plug	5	099 110 712
T-coupling for 2 pole Super Seal plug (3 socketes)	6	099 111 415
Blanking plug for 2 pole Super Seal socket - black plastic	7	099 110 028
Blanking plug for 2 pole Super Seal plug - black plastic	8	099 110 029
Deutsch (DT) plug, with blade receptacles 0,75-2,0 mm <sup>2</sup>	9	098 291 690
Deutsch (DT) socket, with blade terminals 0,75-2,0 mm <sup>2</sup>	10	099 111 043

# Extension- & Y-Adapter cable

Super Seal plug > Super Seal plug

	Application / description	Article No.
	Extension cable, 2 core Super Seal plug > Super Seal plug Conductor cross section: 2x1 mm <sup>2</sup> . Cable type: FLRYY / PVC	
	200 mm	794 002 230
	500 mm	794 005 230
	1.000 mm	794 010 230
	1.500 mm	794 015 230
	2.000 mm	794 020 230
	2.500 mm	794 025 230
	3.000 mm	794 030 230
	5.000 mm	794 050 230
	6.000 mm	794 060 230
	7.500 mm	794 075 230
	10.000 mm	794 100 230
	11.500 mm	794 115 230
	15.000 mm	794 150 230



# Extension- & Y-Adapter cable

Super Seal plug > Super Seal socket

	Application / description	Article No.
	Extension cable, 2 core Super Seal plug > Super Seal socket Conductor cross section: 2x1 mm <sup>2</sup> Cable type: FLRY / PVC	
	1.000 mm	794 010 200
	1.500 mm	794 015 200
	2.000 mm	794 020 200
	3.000 mm	794 030 200
	4.000 mm	794 040 200
	5.000 mm	794 050 200
	6.000 mm	794 060 200
	15.000 mm	794 150 200



# Extension- & Y-Adapter cable

Super Seal socket > Super Seal socket

	Application / description	Article No.
	<p>Extension cable, 2 core Super Seal socket &gt; Super Seal socket Conductor cross section: 2x1 mm<sup>2</sup> Cable type: FLRY Y / PVC</p> <p>1.500 mm</p>	794 015 240

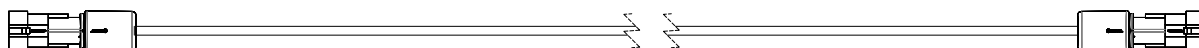

# Extension- & Y-Adapter cable

Super Seal plug > Open end with blade receptacles

	Application / description	Article No.
	Extension cable, 2 core Super Seal plug > Open end with blade receptacles 6,3 x 0,8 mm Conductor cross section: 2x1 mm <sup>2</sup> Cable type: FLRY / PVC	
	500 mm	794 005 251
	1.000 mm	794 010 251
	1.500 mm	794 015 251
	2.000 mm	794 020 251
	4.000 mm	794 040 251
	6.000 mm	794 060 251
	8.000 mm	794 080 251
	10.500 mm	794105 251



# Extension- & Y-Adapter cable

## Deutsch plug (DT2) > Open End

	Anwendung / Beschreibung	Artikel-Nr.
	Extension cable, 2-core Deutsch plug > Open End Conductor cross section: 2x1 mm <sup>2</sup> Cable type: FLRYY / PVC	
	1.500 mm	794 015 255
	2.500 mm	794 025 255

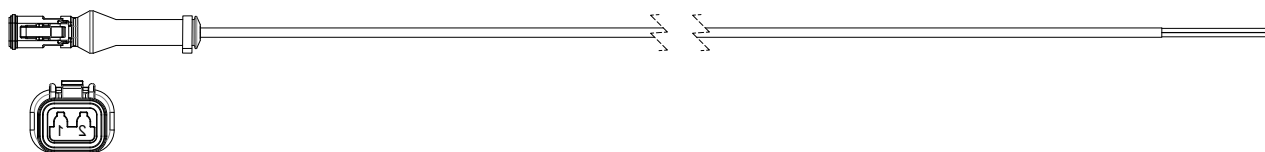

# Extension- & Y-Adapter cable

## Y-Adapter with 3 x Super Seal plugs

	Application / description	Article No.
	Y-Adapter cable, 2 core 1 inlet + 2 outlets with Super Seal plugs Conductor cross section: 2x1 mm <sup>2</sup> Cable type: FLRY Y / PVC	
	2 x 500 mm	894 005 230
	2 x 2000 mm	894 020 230
	2 x 3000 mm	894 030 230
	2 x 4000 mm	894 040 230
	2 x 6000 mm	894 060 230

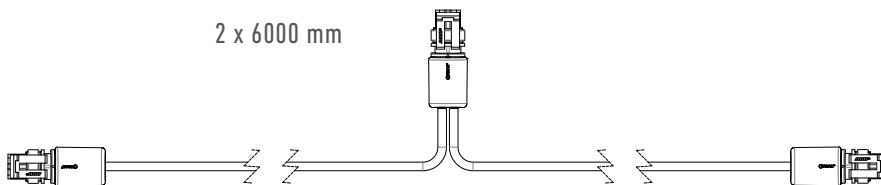

## Side marker cables

	Application / description	Article No.
	Side marker cable, Chain 1 x inlet + 2 x outlets with Super Seal plugs Conductor cross section: 2x0,5 mm <sup>2</sup> Cable type: FLRY Y / PVC	
	3.000 mm Distance between plugs: 1x1700 mm + 1x1300 mm	694 030 200
	4.200 mm Distance between plugs: 1x1200 mm + 1x3000 mm.	694 042 200
	5.300 mm Distance between plugs: 1x300 mm + 1x5000 mm.	694 053 200

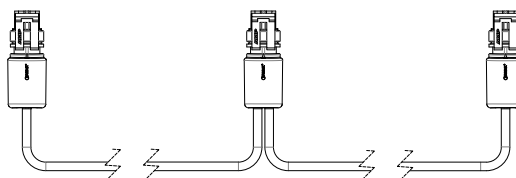

# Extension- & Y-Adapter cable

## Side marker cables

	Application / description	Article No.
	<p>Side marker cable, Chain            1 x inlet + 3 x outlets with Super Seal plugs            Conductor cross section: 2x0,5 mm<sup>2</sup>            Cable type: FLRY / PVC</p> <p>2.500 mm            Distance between plugs: 500 mm + 1500 mm + 500 mm</p> <p>3.200 mm            Distance between plugs: 500 mm + 1700 mm + 1000 mm</p> <p>4.000 mm            Distance between plugs: 1000 mm + 2000 mm + 1000 mm</p> <p>8.000 mm            Distance between plugs: 2000 mm + 2000 mm + 4000 mm</p> <p>9.400 mm            Distance between plugs: 2000 mm + 3700 mm + 3700 mm</p> <p>13.500 mm            Distance between plugs: 4100 mm + 3900 mm + 5500 mm</p>	<p>694 025 300</p> <p>694 032 300</p> <p>694 040 300</p> <p>694 080 300</p> <p>694 094 300</p> <p>694 135 300</p>

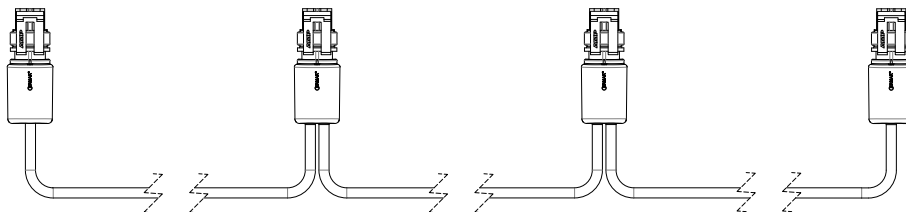



Die Marken der BPW Gruppe:



ERMAX®

HBN-Teknik A/S

HESTAL®

idem  
telematics

Juni 2022 • Version 2.0

ERMAX®

ERMAX A/S  
Vranderupvej 2 • DK-6000 Kolding  
Tel. +45 3969 6800 • [www.ermak.dk](http://www.ermak.dk)